

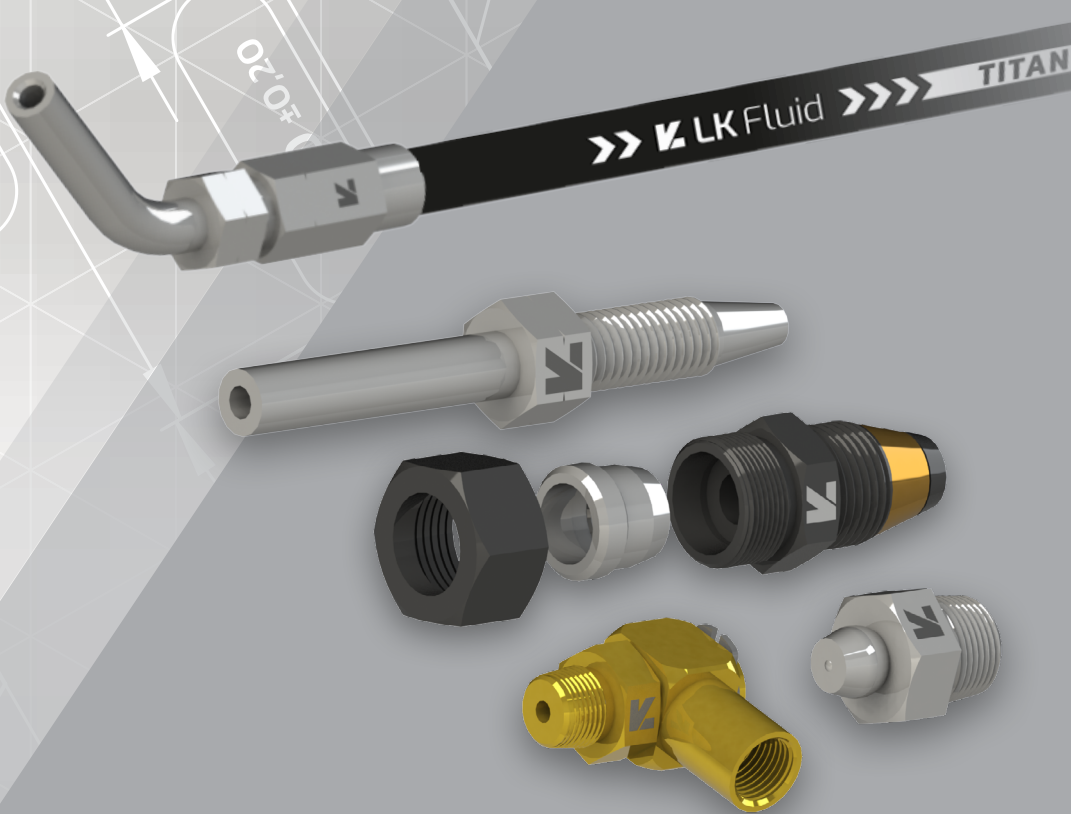

# DMH

## L K F l u i d



# GRAISSAGE

[www.dmhfrance.com](http://www.dmhfrance.com)

**SOMMAIRE**

RÉFÉRENCE	PAGE	RÉFÉRENCE	PAGE
 SOMMAIRE	<b>GR 2</b>	 UNION MALE METRIQUE CONIQUE COMPLET	<b>GR 8</b>
 TUYAU DE GRAISSAGE PA 12 (SANS GRAISSE)	<b>GR 4</b>	 COUDE MALE METRIQUE CONIQUE COMPLET	<b>GR 9</b>
 FOURRURE	<b>GR 4</b>	 UNION MALE BSPT COMPLET	<b>GR 9</b>
 BAGUE BICONE	<b>GR 4</b>	 CLAPET MALE BSPT COMPLET	<b>GR 9</b>
 VIS DE COMPRESSION	<b>GR 4</b>	 COUDE MALE BSPT COMPLET	<b>GR 9</b>
 TUYAU DE GRAISSAGE POLYAMIDE (SANS GRAISSE)	<b>GR 5</b>	 UNION MALE BSPP JE COMPLET	<b>GR 10</b>
 PINCE COUPANTE	<b>GR 5</b>	 UNION FEMELLE METRIQUE PASSE-CLOISON COMPLET	<b>GR 10</b>
 JUPE A VISSER	<b>GR 5</b>	 PROLONGATEUR MALE METRIQUE CONIQUE / FEMELLE METRIQUE	<b>GR 10</b>
 EMBOUT A VISSER LISSE	<b>GR 5</b>	 COUDE MALE METRIQUE CONIQUE / FEMELLE METRIQUE	<b>GR 10</b>
 EMBOUT A VISSER 90° LISSE	<b>GR 6</b>	 COUDE DEPORTE MALE METRIQUE CONIQUE / FEMELLE METRIQUE	<b>GR 11</b>
 EMBOUT A VISSER 90° LISSE HAUTEUR SPECIFIQUE	<b>GR 6</b>	 COUDE 45° MALE METRIQUE CONIQUE / FEMELLE METRIQUE	<b>GR 11</b>
 EMBOUT A VISSER 45° LISSE	<b>GR 6</b>	 COUDE ORIENTABLE FEMELLE BSPP / MALE CONIQUE	<b>GR 11</b>
 ECROU	<b>GR 7</b>	 REDUCTION COURTE PASSE-CLOISON MALE METRIQUE / FEMELLE BSPP	<b>GR 12</b>
 BAGUE COUPANTE	<b>GR 7</b>	 PROLONGATEUR MALE BSPT / FEMELLE METRIQUE	<b>GR 12</b>
 UNION DOUBLE COMPLET	<b>GR 7</b>	 MANCHON FEMELLE METRIQUE	<b>GR 12</b>
 COUDE EGAL COMPLET	<b>GR 7</b>	 MANCHON FEMELLE BSPP	<b>GR 12</b>
 TE EGAL COMPLET	<b>GR 8</b>	 UNION DOUBLE BSPT	<b>GR 13</b>
 CROIX EGALE COMPLET	<b>GR 8</b>	 PROLONGATEUR MALE BSPT / FEMELLE BSPP	<b>GR 13</b>

**SOMMAIRE**

RÉFÉRENCE		PAGE	RÉFÉRENCE		PAGE
	COUDE MALE BSPT / FEMELLE BSPP	GR 13		GRAISSEUR BSPT	GR 19
	COUDE 45° MALE BSPT / FEMELLE BSPP	GR 13		GRAISSEUR 45° BSPT	GR 19
	TE RENVERSE FEMELLE BSPP / MALE BSPT	GR 14		GRAISSEUR 90° BSPT	GR 19
	UNION DOUBLE ENCLIQUETABLE	GR 14		COFFRET DE GRAISSEURS - 160 PCES	GR 19
	CLAPET ENCLIQUETABLE	GR 14		BOUCHON DE GRAISSEUR	GR 20
	ADAPTATEUR ENCLIQUETABLE / MALE METRIQUE CONIQUE	GR 14		SOUPAPE DE DECHARGE	GR 20
	ADAPTATEUR ENCLIQUETABLE / MALE BSPT	GR 15		AGRAFE	GR 20
	COUDE ENCLIQUETABLE / MALE METRIQUE CONIQUE	GR 15		ADAPTATEUR REMPLISSAGE / GRAISSAGE CENTRALISE	GR 21
	COUDE ENCLIQUETABLE / MALE BSPT	GR 15		ADAPTATEUR 90° REMPLISSAGE / GRAISSAGE CENTRALISE	GR 21
	BANJO BSPP JE COMPLET / SERIE LL	GR 16		SERINGUE DE REMPLISSAGE	GR 21
	BANJO SPECIAL GRAISSAGE	GR 16		POMPE A GRAISSE 1 MAIN	GR 21
	BOUCHON MALE ISO	GR 15		BLOC DISTRIBUTEUR EN "L"	GR 22
	COFFRET RACCORDS GRAISSAGE	GR 17		BLOC DISTRIBUTEUR EN "T"	GR 22
	GRAISSEUR METRIQUE CONIQUE	GR 18		COUPLEUR A VISSER SPECIAL GRAISSAGE	GR 22
	GRAISSEUR METRIQUE CONIQUE AUTO-TARAUDANT	GR 18			
	GRAISSEUR 45° METRIQUE CONIQUE	GR 18			
	GRAISSEUR 90° METRIQUE CONIQUE	GR 18			

## TUYAU DE GRAISSAGE

**ZELOS**

Référence	Ø Tuyau	Pression	Ø	Rayon	Poids	
TTGR03-ZEL-V	3 / 1/8"	93	279	6	36	46



**Attention** : la pression de ce tuyau chute à partir de 30 °C

\* Tuyau vide - sans graisse

\*\* Tuyau rempli de graisse EP 2

**Norme de référence** : DIN 73378

**Température** : -40 à + 100 °C

**Revêtement** : PA 12 HL noir

**Application** : graissage / lubrification

## FOURRURE

Référence	A	B	C
GR-FR04L	10,5	3,9	2,5
GR-FR06L	10,5	6,0	2,9

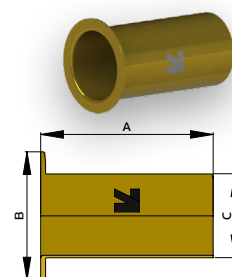

## BAGUE BICONE

Référence	A	B	C
GR-BC04L	4,5	4,1	6,0
GR-BC06L	5	6,1	8,0

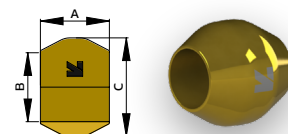

## VIS DE COMPRESSION

Référence	F	A	H
GR-VCBM8X1-ZN	M8X100	12,0	8,0
GR-VCBM10X1-ZN	M10X100	14,0	10,0

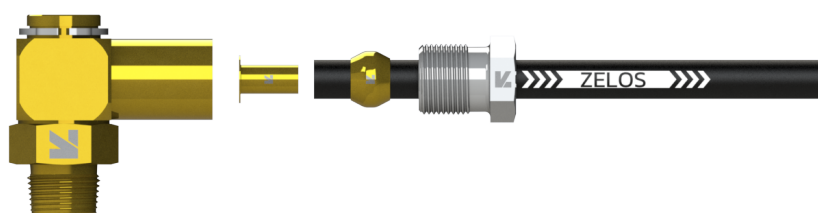
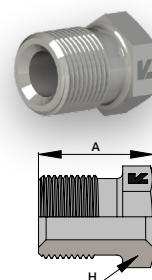

Exemple de montage

GR-BJ1/8KFM10L-SP ■ GR-FR06L ■ GR-BC06L ■ GR-VCBM10X1-ZN ■ TTGR03-ZEL-V

## TUYAU DE GRAISSAGE

**TITAN**

Référence	Ø Tuyau		Pression		Ø	Rayon	Poids	Jupe recommandée
								A visser
TTGRO4-TIT-V*	4	5/32"	280	840	8,6	20	46	GR-RB03-ZN
TTGRO4-TIT-P**	4	5/32"	280	840	8,6	20	46	GR-RB03-ZN
TTGRO6-TIT-V*	6	1/4"	280	840	11,3	20	84	GR-RB04-ZN
TTGRO6-TIT-P**	6	1/4"	280	840	11,3	20	84	GR-RB04-ZN

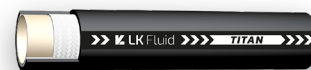

**Norme de référence :** "Design lubrification / graissage"

**Température :** -40 à +80 °C

**Renforcement :** 1 tresse textile

**Revêtement :** thermoplastique noir

**Application :** graissage / lubrification

\* Tuyau vide - sans graisse

\*\* Tuyau rempli de graisse EP 2

## PINCE COUPANTE

Référence

GR-PINCECOUPE

Outil manuel pour couper le tuyau de graissage

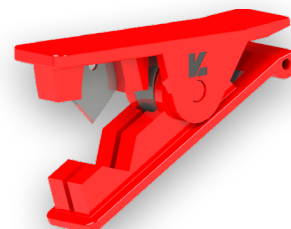

## JUPE A VISSER

Référence	DN	Inch	Int	A	H
GR-RB03-ZN	4	5/32"	7,0	28,0	12
GR-RB04-ZN	6	1/4"	11,0	35,9	17

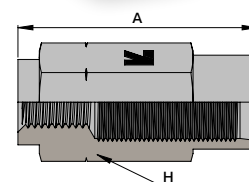
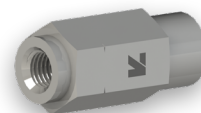

## EMBOU A VISSER LISSE

Référence	DN	Inch	A	D	H	N	PN (bar)
GR-RPDL0306-L20-ZN	4	5/32"	26,0	6,0	10	20,0	280
GR-RPDL0306-ZN	4	5/32"	36,5	6,0	10	30,0	280
GR-RPDL0306-LN-ZN *	4	5/32"	36,0	6,0	10	30,0	280
GR-RPDL0406-ZN	6	1/4"	28,5	6,0	12	22,0	280

\* version Lincoln = pour raccord encliquetable

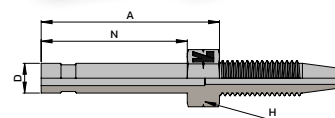
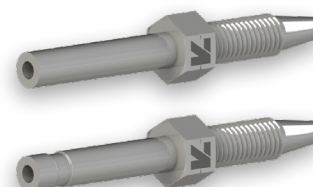

## EMBOUT A VISSER 90° LISSE

Référence	DN	Inch	A	B	D	H	PN (bar)
GR-RP90L0306-ZN	4	5/32"	20,0	32,5	6,0	10	280
GR-RP90L0306-LN-ZN *	4	5/32"	20,0	32,5	6,0	10	280
GR-RP90L0406-ZN	6	1/4"	27,5	45,0	6,0	12	280

\* version Lincoln = pour raccord encliquetable

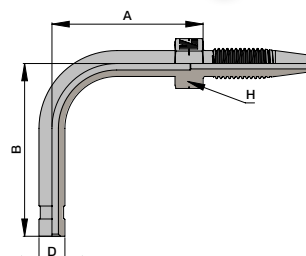
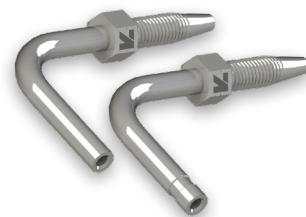

## EMBOUT A VISSER 90° LISSE HAUTEUR SPECIFIQUE

Référence	DN	Inch	A	B	D	H	PN (bar)
GR-RP90L0306H43-ZN	4	5/32"	20,0	43,0	6,0	10	280
GR-RP90L0306H43-LN*	4	5/32"	20,0	43,0	6,0	10	280
GR-RP90L0306H53-ZN	4	5/32"	20,0	53,0	6,0	10	280
GR-RP90L0306H53-LN*	4	5/32"	20,0	53,0	6,0	10	280

\* version Lincoln = pour raccord encliquetable

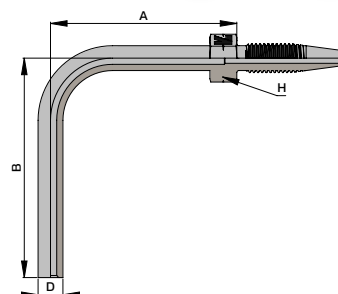

## EMBOUT A VISSER 45° LISSE

Référence	DN	Inch	A	B	D	H	PN (bar)
GR-RP45L0306-ZN	4	5/32"	35,0	20,5	6,0	10	280
GR-RP45L0306-LN-ZN *	4	5/32"	35,0	20,5	6,0	10	280
GR-RP45L0406-ZN	6	1/4"	37,0	25,0	6,0	12	280

\* version Lincoln = pour raccord encliquetable

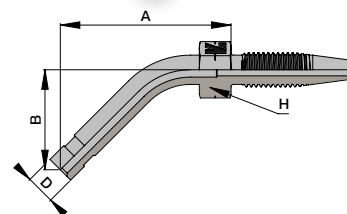
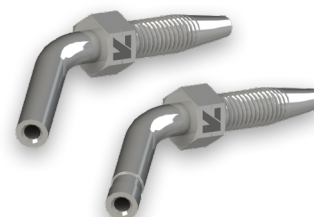

## ECROU

Référence	Ø Tube (mm)	F	A	H
DA-EC06LL-ZN	6LL	M10X100	11,5	12

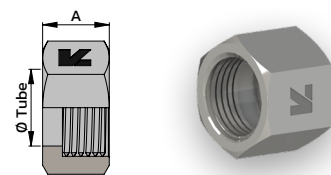

## BAGUE COUPANTE

Référence	Ø Tube (mm)	A
DA-B06LL-ZN	6,0	7,0

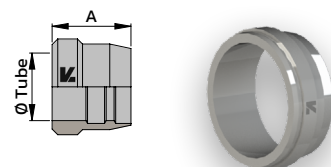

## UNION DOUBLE COMPLET

Référence	Ø Tube (mm)	F	A	H	PN (bar)
DA-UD06LLC-ZN	6,0	M10X100	21,0	11	100

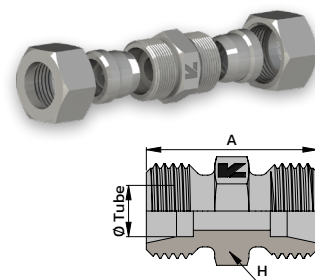

## COUDE EGAL COMPLET

Référence	Ø Tube (mm)	F	A	B	H	PN (bar)
DA-CE06LLC-ZN	6	M10X100	15,0	15,0	9	100

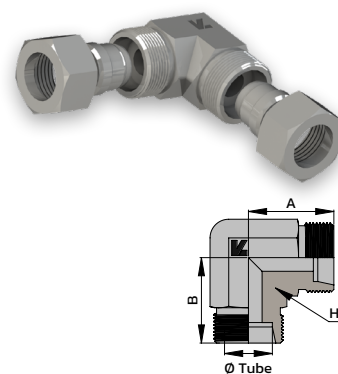

## TE EGAL COMPLET

Référence	Ø Tube (mm)	F	A	B	H	PN (bar)
DA-TE06LLC-ZN	6	M10X100	15,0	15,0	9	100

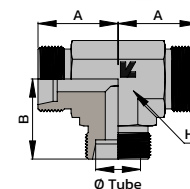
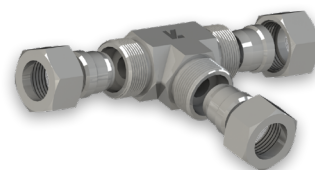

## CROIX EGALE COMPLET

Référence	Ø Tube (mm)	F	A	B	H	PN (bar)
DA-CRE06LLC-ZN	6	M10X100	15,0	15,0	9	100

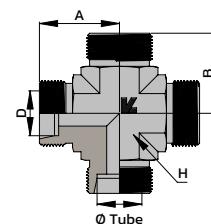
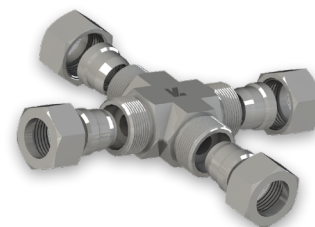

## UNION MALE METRIQUE CONIQUE COMPLET

Référence	Ø Tube (mm)	F	F1	A	H	PN (bar)
DA-UMC06LLM06C-ZN	6,0	M10X100	M6X100	21,0	12	100
DA-UMC06LLM08C-ZN	6,0	M10X100	M8X100	21,0	12	100
DA-UMC06LLMC-ZN	6,0	M10X100	M8X125	22,0	11	100
DA-UMC06LLM10C-ZN	6,0	M10X100	M10X100	21,0	11	100

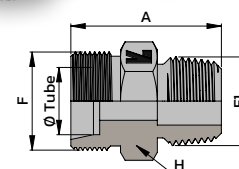
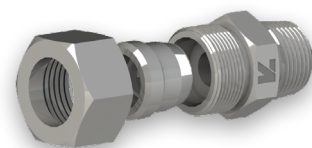

## COUDE MALE METRIQUE CONIQUE COMPLET

Référence	Ø Tube (mm)	F	F1	A	B	H	PN (bar)
DA-CMC06LLM06C-ZN	6,0	M10X100	M6X100	15,0	15,0	11	100
DA-CMC06LLM08C-ZN	6,0	M10X100	M8X100	16,5	15,0	11	100
DA-CMC06LLMC-ZN	6,0	M10X100	M8X125	17,5	15,0	11	100
DA-CMC06LLM10C-ZN	6,0	M10X100	M10X100	16,5	15,0	11	100

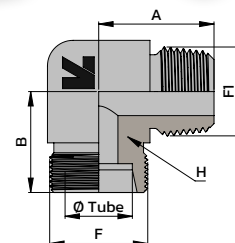
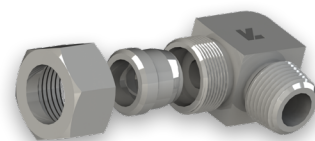

Embout

Protections

DIN

JIC

## UNION MALE BSPT COMPLET

Référence	Ø Tube (mm)	F	F1	A	H	PN (bar)
DA-UMC06LLR1/8C-ZN	6,0	M10X100	1/8"	20,0	11	100

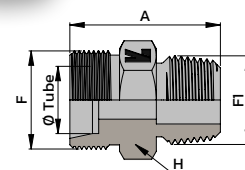
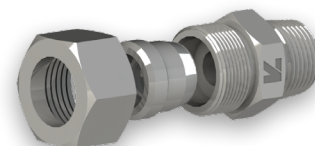

ORFS

BSP

GAZ

## CLAPET MALE BSPT COMPLET

Référence	Ø Tube (mm)	F	F1	A	H	PN (bar)
GR-CLO6LLM10C	6,0	M10X100	M10X100	27,0	11	100

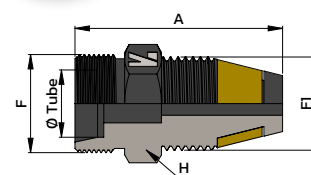

Coupleurs

Vannes Composants

Brides

## COUDE MALE BSPT COMPLET

Référence	Ø Tube (mm)	F	F1	A	B	H	PN (bar)
DA-CMC06LLR1/8C-ZN	6,0	M10X100	1/8"	17,0	15,0	11	100

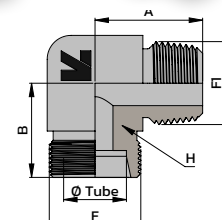
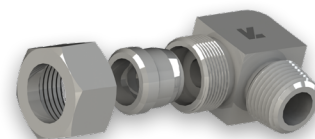

Prises-Pression Manomètres

Colliers

Joint

Lavage

## UNION MALE BSPP JE COMPLET

Référence	Ø Tube (mm)	F	F1	A	H	PN (bar)
DA-UM06LLR1/8JEC-Z	6,0	M10X100	1/8"	21,5	14	100

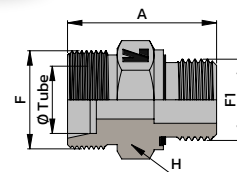
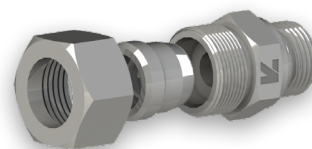

## UNION FEMELLE METRIQUE PASSE-CLOISON COMPLET

Référence	Ø Tube (mm)	F	F1	A	H	H1	PN (bar)
GR-UM06LLPCLMF6-ZN	6,0	M10X100	M6X100	35,0	12	17	100

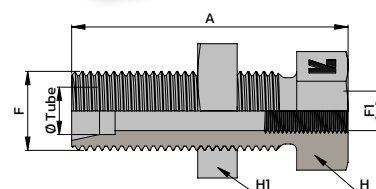
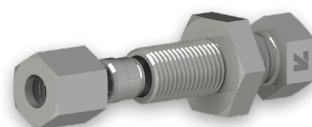

## PROLONGATEUR MALE METRIQUE CONIQUE / FEMELLE METRIQUE

Référence	F	F1	A	H	PN (bar)
GR-APMFM8x1CO-ZN	M8X100	M8X100	18,0	12	100
GR-APMFM8x1CO-L30	M8X100	M8X100	28,0	12	100
GR-APMFM8125CO-L30	M8X125	M8X125	28,0	12	100
GR-APMFM10X1CO-ZN	M10X100	M10X100	18,0	13	100
GR-APMFM10X1CO-L25	M10X100	M10X100	25,0	13	100
GR-APMFM10X1CO-L35	M10X100	M10X100	35,0	13	100
GR-APMFM10X1CO-L50	M10X100	M10X100	50,0	13	100
GR-APMFM10X1COL100	M10X100	M10X100	100,0	13	100
GR-APMFM10X1COL150	M10X100	M10X100	150,0	13	100

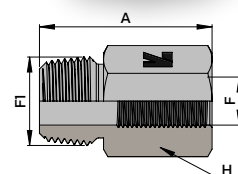
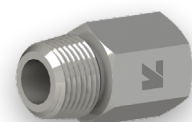

## COUDE MALE METRIQUE CONIQUE / FEMELLE METRIQUE

Référence	F	F1	A	B	H	PN (bar)
GR-CMFM1010CO-ZN	M10X100	M10X100	17,5	6,5	13	100

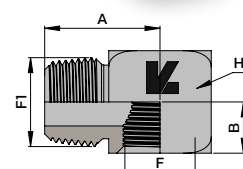
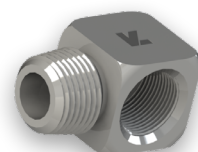

## COUDE DEPORTE MALE METRIQUE CONIQUE / FEMELLE METRIQUE

Référence	F	F1	A	H	D	O'ring	PN (bar)
<b>GR-CMFM1010CO-ZNM1</b>	M10X100	M10X100	39,0	30	20,0	Ø23,52X1,78	100

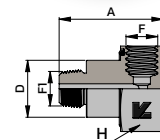

Référence	F	F1	A	H	D	PN (bar)
<b>GR-CMFM1010CO-ZNM2</b>	M10X100	M10X100	42,0	22	20,0	100
<b>GR-CMFM1010CO-ZNM3</b>	M10X100	M10X100	50,0	24	23,7	100

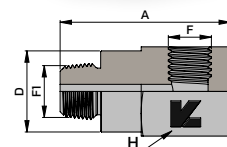
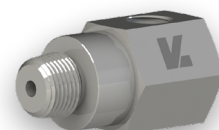

## COUDE 45° MALE METRIQUE CONIQUE / FEMELLE METRIQUE

Référence	F	F1	A	H	PN (bar)
<b>GR-C45MFM1010CO-ZN</b>	M10X100	M10X100	19,0	13	100

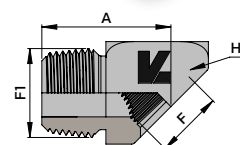
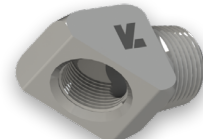

## COUDE ORIENTABLE FEMELLE BSPP / MALE CONIQUE

Référence	F	F1	A	B	H	H1	PN (bar)
<b>GR-BJ1/8KFM10L-SP</b>	1/8"	M10X100	20,5	21,9	15	14	100
<b>GR-BJ1/8KFG02L-SP</b>	1/8"	1/8"	20,5	21,9	15	14	100

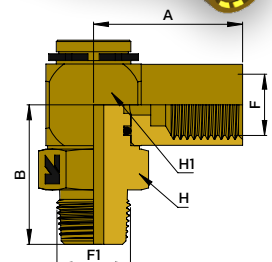

## REDUCTION COURTE PASSE-CLOISON MALE METRIQUE / FEMELLE BSPP

Référence	F	F1	A	H	H1	PN (bar)
GR-ARMFCM1602-PCL	M16X150	1/8"	18,0	19	19	100

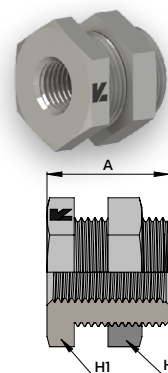

## PROLONGATEUR MALE BSPT / FEMELLE METRIQUE

Référence	F	F1	A	H	PN (bar)
GR-AMFKM0410-ZN	M10X100	1/4"	24,0	14	100

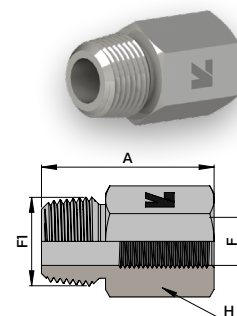

## MANCHON FEMELLE METRIQUE

Référence	F	A	H	PN (bar)
GR-APFFM1010-ZN	M10X100	25,0	14	280

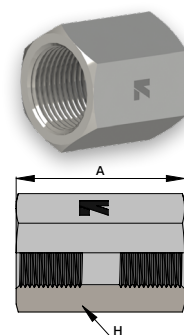

## MANCHON FEMELLE BSPP

Référence	F	A	H	PN (bar)
GR-APFFG0202-ZN	1/8"	23,0	14	280

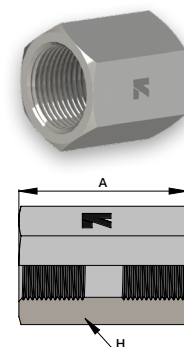

## UNION DOUBLE BSPT

Référence	F	F1	A	H	PN (bar)
GR-ANKK0202-ZN	1/8"	1/8"	21,0	11	100

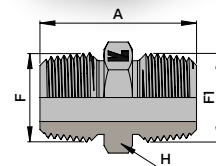
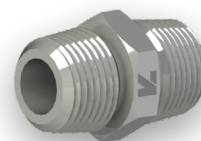

## PROLONGATEUR MALE BSPT / FEMELLE BSPP

Référence	F	F1	A	H	PN (bar)
GR-APMFG02CO-ZN	1/8"	1/8"	18,0	13	100

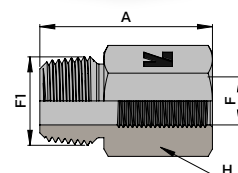
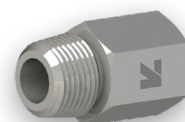

## COUDE MALE BSPT / FEMELLE BSPP

Référence	F	F1	A	B	H	PN (bar)
GR-CMF0202CO-ZN	1/8"	1/8"	17,5	6,5	13	100

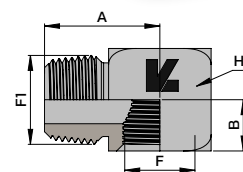
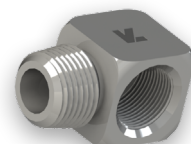

## COUDE 45° MALE BSPT / FEMELLE BSPP

Référence	F	F1	A	H	PN (bar)
GR-C45MF0202CO-ZN	1/8"	1/8"	19,0	13	100

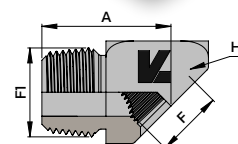
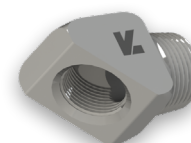

### TE RENVERSE FEMELLE BSPP / MALE BSPT

Référence	F	F1	F2	A	B	H	PN (bar)
GR-TFMRO2-ZN	1/8"	1/8"	1/8"	39,5	21,0	10	100

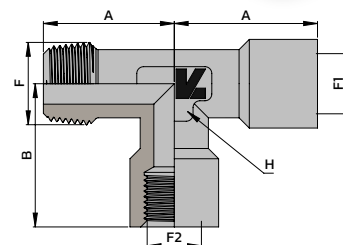
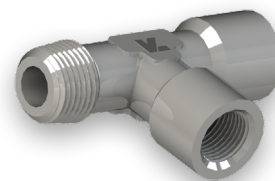

### UNION DOUBLE ENCLIQUETABLE

Référence	A	Ø Tube (mm)	PN (bar)
GR-UDEN06	33,0	6,0	200

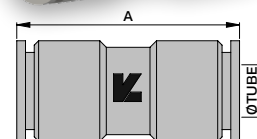
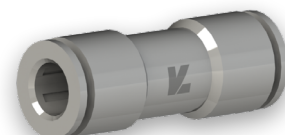

### CLAPET ENCLIQUETABLE

Référence	F	A	Ø Tube (mm)	H	PN (bar)
GR-CLEN06M10	M10X100	37,0	6,0	12	200

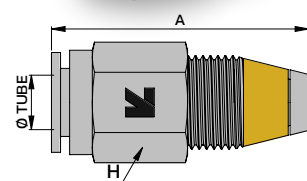

### ADAPTATEUR ENCLIQUETABLE / MALE METRIQUE CONIQUE

Référence	F	A	Ø Tube (mm)	H	PN (bar)
GR-UMEN04M06CO	M6X100	24,5	4,0	8	200
GR-UMEN04M10CO	M10X100	19,7	4,0	12	200
GR-UMEN06M06CO	M6X100	27,0	6,0	12	200
GR-UMEN06M08CO	M8X100	28,0	6,0	12	200
GR-UMEN06M10CO	M10X100	24,0	6,0	12	200

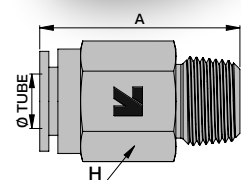

## ADAPTATEUR ENCLIQUETABLE / MALE BSPT

Référence	F	A	Ø Tube (mm)	H	PN (bar)
<b>GR-UMEN06R1/8CO</b>	1/8"	22,6	6,0	12	200

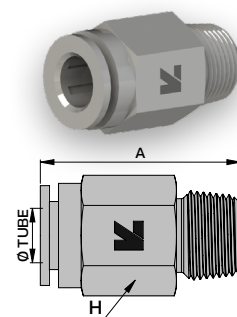

## COUDE ENCLIQUETABLE / MALE METRIQUE CONIQUE

Référence	F	A	B	Ø Tube (mm)	H	PN (bar)
<b>GR-CEN04M06CO</b>	M6X100	20,5	14,5	4,0	8	200
<b>GR-CEN04M10CO</b>	M10X100	20,5	17,6	4,0	8	200
<b>GR-CEN06M06CO</b>	M6X100	24,1	16,5	6,0	10	200
<b>GR-CEN06M06CO-RO*</b>	M6X100	26,2	24,8	6,0	10	200
<b>GR-CEN06M08CO</b>	M8X100	24,1	16,5	6,0	10	200
<b>GR-CEN06M08CO-RO*</b>	M8X100	26,2	24,5	6,0	10	200
<b>GR-CEN06M10CO</b>	M10X100	24,1	17,5	6,0	10	200
<b>GR-CEN06M10CO-RO*</b>	M10X100	26,2	24,0	6,0	10	200

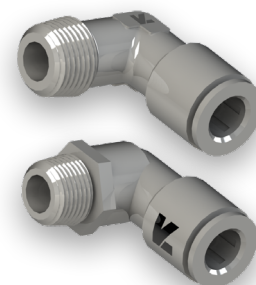

\* Rotatif

## COUDE ENCLIQUETABLE / MALE BSPT

Référence	F	A	B	Ø Tube (mm)	PN (bar)
<b>GR-CEN06R1/8CO</b>	1/8"	24,1	17,5	6,0	200
<b>GR-CEN06R1/8CO-RO*</b>	1/8"	24,1	23,4	6,0	200

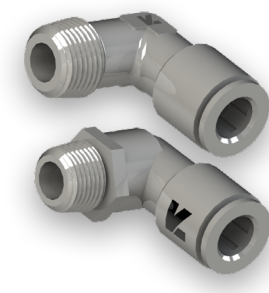

\* Rotatif

### BANJO BSPP JE COMPLET / SERIE LL

Référence	Ø Tube (mm)	F1	F1	A	B	L	H	H1	PN (bar)
DA-BJE06LLR1/8C-ZN	6LL	M10X100	1/8"	26,5	18,0	12,5	17	17	100

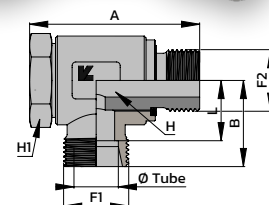
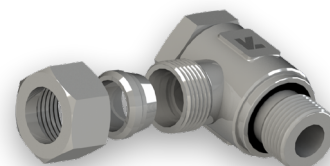

### BANJO SPECIAL GRAISSAGE

Référence	F	F1	F2	A	D	H	PN (bar)
GR-BJ10X100-SP	M10X100	1/8"	M10X100	35,0	30	17	100
GR-BJ1/8-SP	1/8"	1/8"	M10X100	35,0	30	17	100

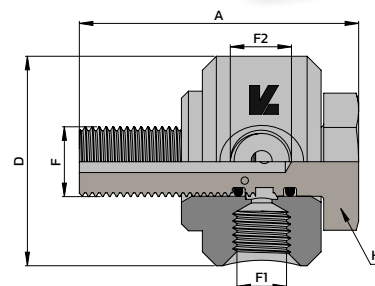

### BOUCHON MALE ISO

Référence	F	A	H	PN (bar)
GR-BM10X100ISO	M10X100	8,5	5,0	100

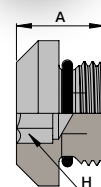
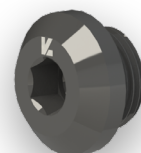

**COFFRET RACCORDS GRAISSAGE**

Référence	L (mm)	l (mm)	H (mm)	Emplacement
<b>COF-GR-RACCORD</b>	380,0	310,0	70	23
<b>COF-23-VIDE*</b>	380,0	310,0	70	23

\* = COFFRET NU

Référence	Quantité
GR-RB03-ZN	20
GR-RPDLO306-ZN	10
GR-RP45LO306-ZN	5
GR-RP90LO306-ZN	10
DA-UMCO6LLM06C-ZN	10
DA-CMCO6LLM06C-ZN	5
GR-UM06LLPCLMF6-ZN	5
GR-CLO6LLM10C	5
DA-UMCO6LLM08C-ZN	10
DA-CMCO6LLM08C-ZN	5
DA-UD06LLC-ZN	5
DA-CE06LLC-ZN	5
DA-UMCO6LLR1/8C-ZN	10
DA-CMCO6LLR1/8C-ZN	5
GR-APMFG02CO-ZN	10
GR-CMF0202CO-ZN	10
GR-C45MF0202CO-ZN	5
GR-BM10X100ISO	20
GR-C45MFM1010CO-ZN	5
GR-CMFM1010CO-ZN	10
GR-APMFM10X1CO-ZN	10
GR-BLOC2-10X100-ZN	1
GR-BLOC4-10X100-ZN	1
GR-PINCE	1
GR-BJ1/8KFM10L-SP	3



## GRAISSEUR METRIQUE CONIQUE

Référence	F	A	H
GR-GRM06CO	M6X100	15,0	7
GR-GRM08CO	M8X100	15,0	9
GR-GRM08125CO	M8X125	15,0	9
GR-GRM10CO	M10X100	15,0	11
GR-GRM10150CO	M10X150	15,0	11

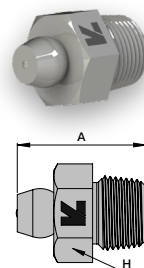

## GRAISSEUR METRIQUE CONIQUE AUTO-TARAUDANT

Référence	F	A	H
GR-GRM06CO-ATT	M6X100	15,0	7
GR-GRM08CO-ATT	M8X100	15,0	9

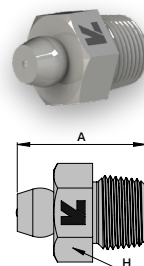

## GRAISSEUR 45° METRIQUE CONIQUE

Référence	F	A	B	H
GR-GR45M06CO	M6X100	13,0	13,0	9
GR-GR45M08CO	M8X100	13,0	13,0	9
GR-GR45M08125CO	M8X125	13,0	13,0	9
GR-GR45M10CO	M10X100	13,0	14,0	11
GR-GR45M10150CO	M10X150	15,0	14,0	11

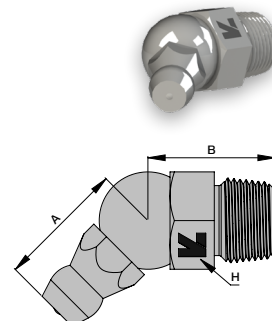

## GRAISSEUR 90° METRIQUE CONIQUE

Référence	F	A	B	H
GR-GR90M06CO	M6X100	13,0	13,0	9
GR-GR90M08CO	M8X100	13,0	13,0	9
GR-GR90M08125CO	M8X125	13,0	13,0	9
GR-GR90M10CO	M10X100	15,0	15,0	11

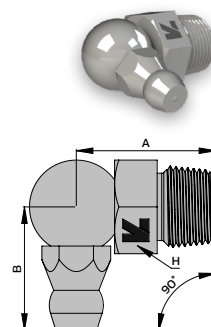

## GRAISSEUR BSPT

Référence	F	A	H
GR-GRMCO2	1/8"	15,0	11
GR-GRMCO4	1/4"	17,5	14

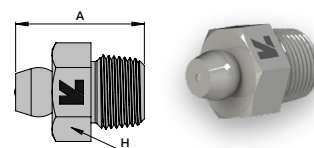

## GRAISSEUR 45° BSPT

Référence	F	A	B	H
GR-GR45MCO2	1/8"	13,0	16,5	11
GR-GR45MCO4	1/4"	13,0	18,5	14

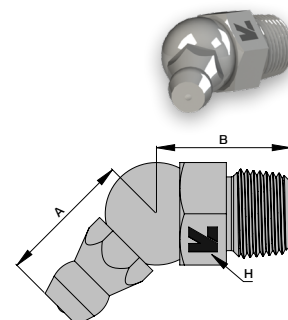

## GRAISSEUR 90° BSPT

Référence	F	A	B	H
GR-GR90MCO2	1/8"	17,0	14,0	11
GR-GR90MCO4	1/4"	19,0	14,0	14

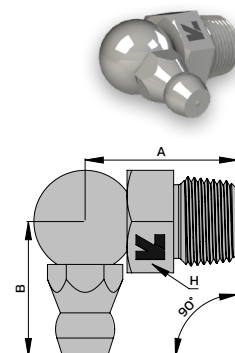

## COFFRET DE GRAISSEURS - 160 PCES

Référence	L (mm)	l (mm)	H (mm)	Emplacement
COF-GR-GRAISSEUR	230,0	120,0	45	15

Référence	Quantité	Référence	Quantité
GR-GRM06CO	40	GR-GR45M10CO	5
GR-GRM08CO	30	GR-GR45M08125CO	5
GR-GRM10CO	20	GR-GR45M10150CO	5
GR-GRM08125CO	10	GR-GR90M06CO	5
GR-GRMCO4	10	GR-GR90M08CO	5
GR-GRM10150CO	5	GR-GR90M10CO	5
GR-GR45M06CO	5	GR-GR90M08125CO	5
GR-GR45M08CO	5		

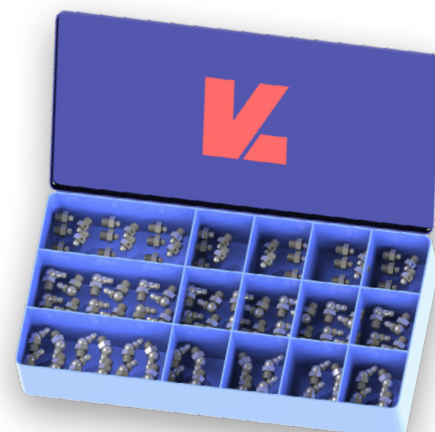

## BOUCHON DE GRAISSEUR

Référence	Couleur	Matière	A	D1	D2
GR-BPGRR	Rouge	PE	29,0	6,3	5,7
GR-BPGRV	Vert	PE	29,0	6,3	5,7
GR-BPGRB	Bleu	PE	29,0	6,3	5,7
GR-BPGRJ	Jaune	PE	29,0	6,3	5,7
GR-BPGRN	Noir	PE	29,0	6,3	5,7

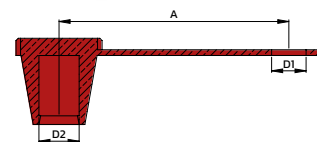
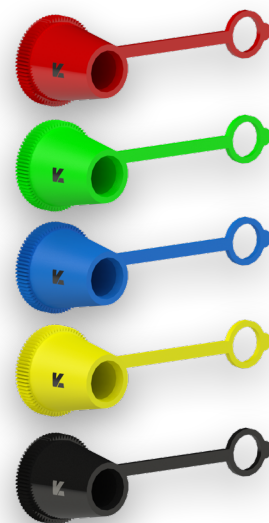

## SOUPAPE DE DECHARGE

Référence	F	A	H	Tarage (Bar)
GR-SDD02CO	1/8"	14	11	3

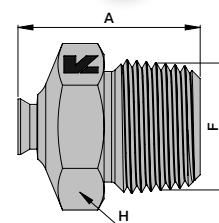
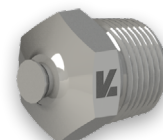

## AGRAFE

Référence	F
GR-AGRAFEM10	M10X100
GR-AGRAFSECUM10	M10X100

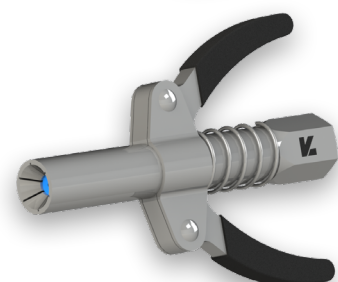
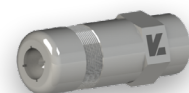

## ADAPTATEUR REMPLISSAGE / GRAISSAGE CENTRALISE

Référence	F	F1	A	H	PN (bar)
<b>GR-GMINI-ADREM</b>	M28X200	M20X150	56,5	30	200
<b>GR-G3-ADREM</b>	M28X200	3/4" UNF	61,5	30	200

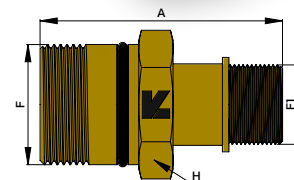
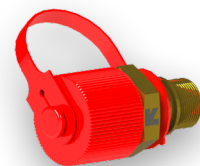

## ADAPTATEUR 90° REMPLISSAGE / GRAISSAGE CENTRALISE

Référence	F	F1	A	H	PN (bar)
<b>GR-GMINI-AMFDREM</b>	M22X150	M20X150	47,0	30	200
<b>GR-G3-AMFDREM</b>	M22X150	3/4" UNF	52,0	30	200

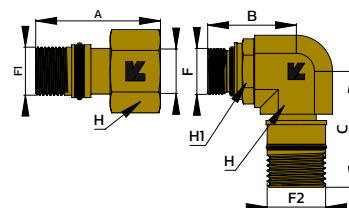
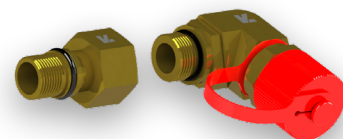

## SERINGUE DE REMPLISSAGE

### Référence

**GR-SDREM**

Pour cartouche de graisse Ø 53 x Lg 240 mm  
Vendue sans graisse

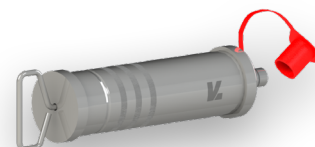

## POMPE A GRAISSE 1 MAIN

### Référence

**GR-PUMP1H**

Pour cartouche de graisse Ø 53 x Lg 240 mm  
Vendue sans graisse



## BLOC DISTRIBUTEUR EN "L"

Référence	F	A	B	C	D
GR-BLOC1-10X100-ZN	2X M10X100	30,0			6,5
GR-BLOC2-10X100-ZN	4X M10X100	60,0	50,0	22,0	6,5
GR-BLOC3-10X100-ZN	6X M10X100	84,0	74,0	22,0	6,5
GR-BLOC4-10X100-ZN	8X M10X100	106,0	96,0	22,0	6,5
GR-BLOC5-10X100-ZN	10X M10X100	128,0	118,0	22,0	6,5
GR-BLOC6-10X100-ZN	12X M10X100	150,0	140,0	22,0	6,5
GR-BLOC8-10X100-ZN	16X M10X100	194,0	184,0	22,0	6,5

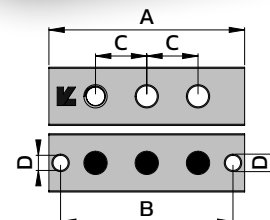
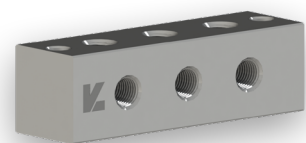

## BLOC DISTRIBUTEUR EN "T"

Référence	F	A	B	C	D
GR-BLOC1T-02-ZN	3X 1/8"	30,0			6,5
GR-BLOC2T-02-ZN	6X 1/8"	60,0	50,0	22,0	6,5
GR-BLOC3T-02-ZN	9X 1/8"	84,0	74,0	22,0	6,5
GR-BLOC4T-02-ZN	12X 1/8"	106,0	96,0	22,0	6,5
GR-BLOC5T-02-ZN	15X 1/8"	128,0	118,0	22,0	6,5

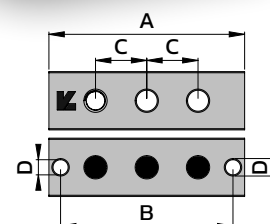
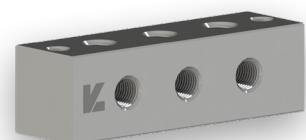

## COUPLEUR A VISSER SPECIAL GRAISSAGE

Référence	A	B	D	F	F1	H1	H2	H3
GR-CFV02M10	78,5	-	-	O6L - M12X150	6LL - M10X100	46	30	27
GR-CMV02M10	-	51,5	55	O6L - M12X150	-	-	-	-

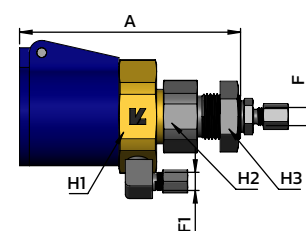
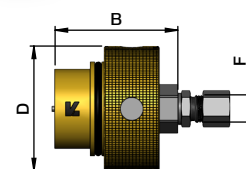
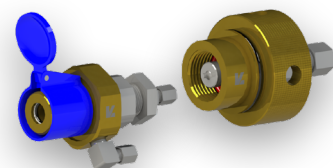

**NOTES**



## DMH, FOURNISSEUR DE CONNECTIQUE HYDRAULIQUE

Chez DMH France, nous nous engageons à fournir à nos clients les solutions les plus adaptées à leur besoin, grâce à un service efficace et dans les meilleurs délais.

Pour cela, nous avons développé la marque LK Fluid, une gamme complète de connecteurs hydraulique de haute qualité.

Les produits LK Fluid bénéficient d'une capacité de stockage de plus de 5000 m<sup>2</sup>, permettant une forte disponibilité et de faibles délais de livraison.

Ciblant principalement le marché européen, DMH fournit les grands constructeurs ainsi que les spécialistes de la distribution (machines agricoles, poids lourds, industries, etc.).

Nos 20 années d'expérience nous ont permis de construire de forts partenariats avec nos clients, les accompagnant dans leur poursuite d'excellence.

### UNE GAMME COMPLETE DE PRODUITS HYDRAULIQUES



#### DMH ■ Agence de Nantes

6 rue Jupiter 44470 Carquefou FRANCE  
T +33 (0)2 40 25 77 27  
distribution@dmhfrance.com  
oem@dmhfrance.com

#### DMH ■ Agence de Lyon

5 av. Lionel Terray 69330 Meyzieu FRANCE  
T +33 (0)4 37 25 84 50  
infolyon@dmhfrance.com

[www.dmhfrance.com](http://www.dmhfrance.com)



DMH France certifiée ISO 9001:2015

